

CHASE SECTION (TYP.)

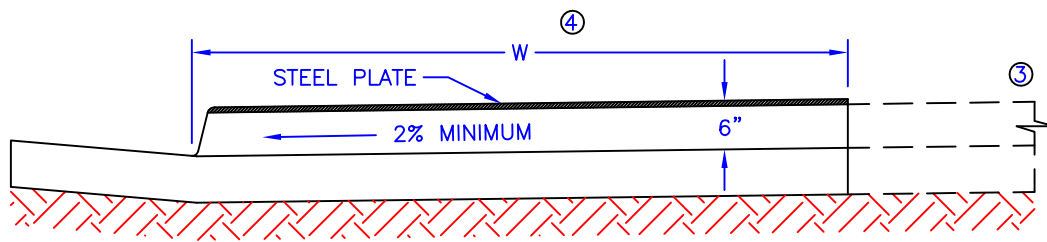

SIDE VIEW

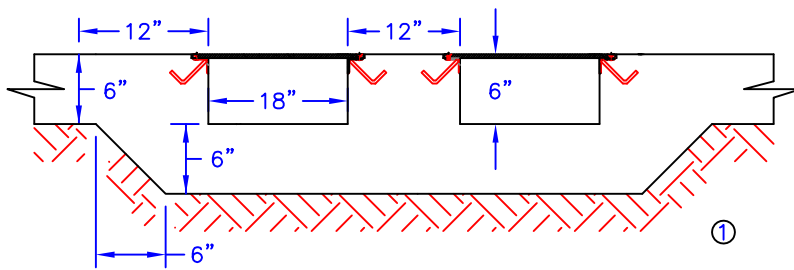

MULTIPLE CHASE

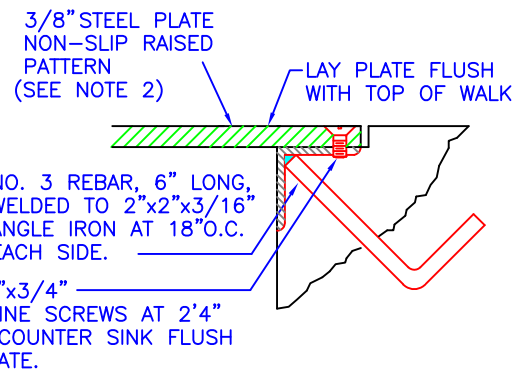

DETAIL D

NO SCALE

NOTES:

- ① COMPACTED SUBGRADE MATERIAL
- ② CHASE SECTIONS WITHIN 25' OF INTERSECTIONS OR DRIVEWAYS ARE REQUIRED TO USE 1/2" STEEL PLATE
- ③ CONSTRUCT CONCRETE CHANNEL WHERE REQUIRED
- ④ W = 5' 6" OR MATCH EXISTING

<p>ADAMS COUNTY TRANSPORTATION DEPARTMENT /ENGINEERING</p> <p>4430 S. ADAMS COUNTY PKWY. BRIGHTON, CO 80601</p>	<h2>SIDEWALK CHASE DETAILS</h2> <p>REVISION DATE: 06/02/14      FILE NAME: SWLK_CHASE_D.DWG</p>	<p>ADAMS COUNTY TRANSPORTATION DEPARTMENT /CONSTRUCTION INSPECTION</p> <p>4430 S. ADAMS COUNTY PKWY. BRIGHTON, CO 80601</p>
---	---	---